

Tech Challenge 2019

Tech Challenge consists of five events for individual, pair, and teams. These events represent basic skills that every theatre technician needs.

The following Tech Challenge event requirements were designed by professionals, educators, and the Educational Theatre Association. Please use this guide to help your team prepare. A Tech Challenge team can have up to seven members; see event descriptions for details. Each team carries a team score sheet. The definitions of the boldface words found throughout this guide are in the vocabulary section at the back.

EdTA recognizes that there are a variety of methods and materials used to execute these tasks. The methods described in this guide have been developed by experienced theatre technicians. Participants are expected to follow the instructions outlined here and will be scored accordingly.

All teams are required to show good sportsmanship, which means being respectful and supportive of other teams. Teams showing good sportsmanship may be rewarded with additional time deductions, and teams showing poor sportsmanship may receive penalties. If poor behavior continues a team may be removed from the event.

The 2019 events

1. Lighting: Hang and focus a lighting instrument
2. Rigging: Knot tying
3. Scenery: Fold a theatrical backdrop
4. Costuming: Thread a sewing machine
5. Scenery: Leg a platform

A penalty has been added to each event for blatant disregard for the rules. This penalty ensures that no team will do an event as quickly as possible, take all penalties, and still win. This is cheating, and teams will be penalized or disqualified. All participants must wear closed-toed shoes on the event floor. If the judges determine a student is not wearing appropriate footwear, the student will not be allowed to compete. Students will be timed at each event and given time additions for any penalties. Each team will then be ranked in each event. These ranks will be tallied to determine the winners in each event.

LIGHTING

Lighting provides a tool for setting the mood of a scene. The responsibility of hanging and focusing the lights for a show falls on the hang crew, overseen by the **master electrician (M.E.)**. There are many different types of lighting instruments that the M.E. will use in the theatre. Each type of instrument plays an important role in the overall lighting scheme. It is important that the M.E. has a broad understanding of all of these instruments, how they are installed, and how they are focused. One of the instruments that you will use the most is the **ellipsoidal reflector spotlight**. There are many types of ellipsoidal spotlights from different manufacturers and different eras; one of the most common is the **ETC Source 4 Ellipsoidal Spotlight**.



ETC Source 4

Tech Challenge Event: Hang and focus a lighting instrument

Individual Event

Two people per team can compete in this event, and each gets two tries.

The master electrician uses many different kinds of lighting instruments. In this challenge, participants will be asked to successfully hang and focus an ETC Source 4 Ellipsoidal Spotlight. All equipment and tools will be provided, but participants can bring their own gloves and adjustable crescent wrench.

Rules

1. Participants must wear gloves on both hands at all times and are allowed to use any adjustable lighting tool (e.g., Mega Combo Wrench, Ultimate Flat Focus Tool, ratcheting wrench). No fingerless gloves. Participants may wear an apron.
2. Items should never be tethered around a participant's neck or over the shoulder. Please note that items that fall from the apron will be counted the same as dropping an item.
3. Participants must not carry gel frames in a pocket.
4. Participant must provide the sharpest possible focus of the fixture within the tape outline. When the unit is secured properly to the pipe, powered on, and correctly focused to the shape marked out on the wall, then the event has been successfully completed. The ETC Source 4 Ellipsoidal has a drop-in iris slot on the top of the fixture. The gel clip holder should also be on this side of the fixture. The gel clip holder needs to be on top of the fixture when it is focused.
5. The maximum time allotted is three (3) minutes.

How to hang an ETC Source 4 Ellipsoidal Spotlight

1. Place a **C-clamp** over the pipe at the designated hanging location. The opening of the C-clamp must face downstage of the electric pipe and toward the person installing the fixture, enabling unobstructed access to bolts.
2. Finger-tighten the pipe bolt.
3. Attach the **safety cable** through the **yoke** and around the electric pipe.
4. Tighten the pipe bolt and adjust the C-clamp as necessary so that it is secure on the electric pipe. The pipe bolt should be no tighter than one quarter turn past finger tight.
5. Pull all of the shutters in the fixture to open.
6. Plug the **tail** of the lighting instrument into the designated **circuit**.

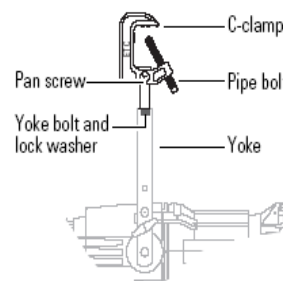

How to focus an ETC Source 4 Ellipsoidal Spotlight

1. Adjust the **pan** of the unit so that it is set in the desired location.
2. Adjust the **tilt** of the unit so that it is set in the desired location.
3. **Focus** the **beam** to the desired beam edge.
4. Using the **shutters** and the rotation knob as necessary, shape the beam to the desired shape and angle.
5. Make sure all nuts, handles, and knobs are tightened so the instrument does not **drop focus**.
6. Drop **color** into the color slot of the instrument.

How to set the angle within the yoke

1. Loosen the yoke locking knobs. Do not remove them.
2. Tilt the fixture to the desired position.
3. Tighten the yoke locking knobs to secure the fixture in position.

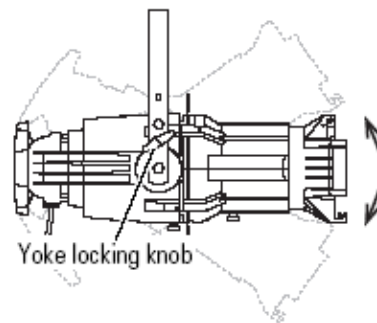

How to focus the beam

1. Loosen the beam focus knob located under the barrel.
2. Slide the lens tube forward or backward to achieve the desired beam edge.
3. Once the fixture is focused, tighten the beam focus knob.

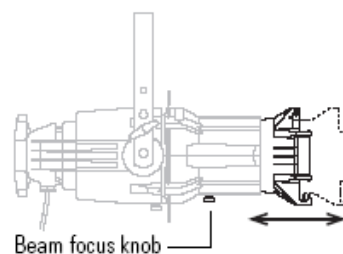

How to rotate the angle within the fixture

1. Loosen the rotation locking knob. Do not remove it.
2. Rotate the barrel of the fixture left or right to the desired position.
3. Recheck the focus of the beam for sharp or soft focus and then tighten the rotation locking knob to secure the fixture in position.

Recommended sequence

1. Participants can ask questions prior to start.
2. Leave the starting line after starting the timer.
3. Locate the fixture.
4. Hang the fixture.
5. Hand-tighten the C-clamp.
6. Install the safety cable.
7. Wrench-tighten the C-clamp.
8. Check and tighten as necessary the yoke bolt on the side and bottom of the C-clamp.
9. Open the shutters on the fixture.
10. Plug the fixture into power.
11. Position the fixture (pan and tilt) to illuminate the shape.
12. Lock the fixture.
13. Place the fixture in a sharp focus so that the edge is on the tape.
14. Make shutter cuts as necessary.
15. Review fixture focus and make adjustments as necessary.
16. Insert gel frame.
17. Return to starting line and stop the timer.
18. Assist judges in restoring all equipment to pre-event conditions.

Penalties: Hang and focus a light

Add the following time for:

- | | |
|---|--------------|
| • Placing items in mouth | 10 seconds |
| • Dropping items or placing on the ground | 10 seconds |
| • Gloves not worn, beginning to completion | 10 seconds |
| • Items tethered around neck | 10 seconds |
| • Gel frame not installed properly or forgotten | 10 seconds |
| • C-clamp opening not facing installer | 5 seconds |
| • Instrument hung upside down | 15 seconds |
| • Safety cable not used properly | 10 seconds |
| • Any item not tightened | 10 seconds |
| • Failure to complete a step | 10 seconds |
| • Shutter cut inside/outside shape | 5 seconds |
| • Focus is not sharp | 5 seconds |
| • Blatant disregard for the rules | disqualified |

RIGGING

Tying basic knots is an essential skill for a wide range of technicians who use it for everything from hauling equipment to the **catwalk** to properly **rigging** scenery.

Tech Challenge Event: Knot tying

Individual Event

Two people per team can compete in this event, and each gets two tries.

In this challenge, individuals will be asked to correctly tie a series of commonly used knots for properly rigging scenery. Participants must tie knots correctly with a minimum of a 6" tail on all knot ends. Task completed when the contestant stops the timer. All ropes must be on the ground prior to attempt. The maximum time allotted is two (2) minutes.

Rules and required sequence

1. Start the timer
2. Tie a clove hitch on the pipe stand.
3. Tie a half hitch to secure the clove hitch.
4. Tie a second line to the first with a sheet bend. Participants must put the tails for the sheet bend on the same side.
5. Use the end of the second line and tie a bowline. Participants must put the tail for the bowline on the inside of the loop.
6. Contestant then stops the timer.

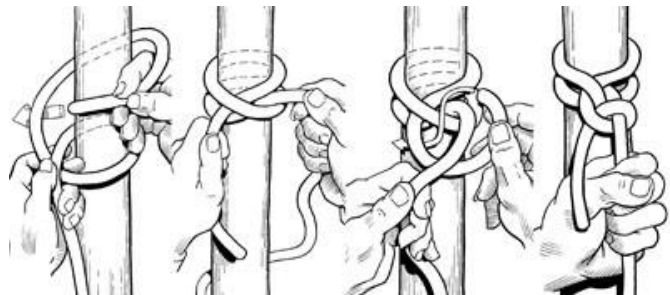
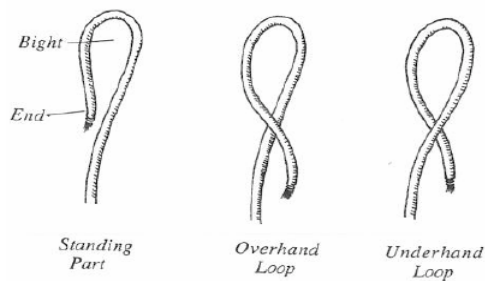

Knot terminology

Clove hitch with half hitch

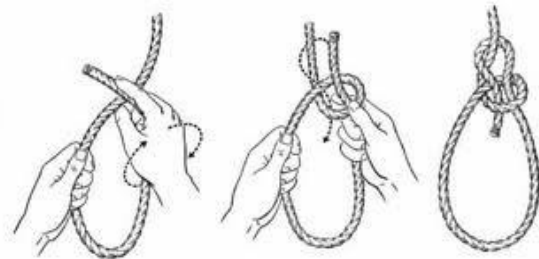
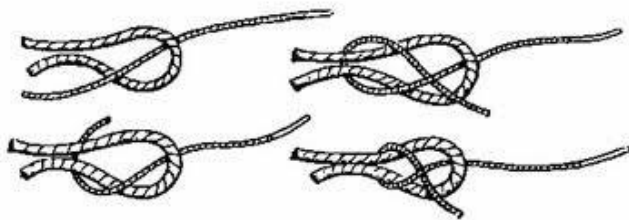

Sheet bend

Bowline

Penalties: Knot tying

Add the following time for:

- | | |
|---|--------------|
| • Placing rope in the mouth | 5 seconds |
| • Failed or incorrectly tied knots (penalty for each) | 5 seconds |
| • Not having a minimum of 6" tail on all knot ends | 2 seconds |
| • Blatant disregard for the rules | disqualified |

SCENERY

When not hung on a batten for show use, there are particular ways soft goods should be folded and stored. There are many ways to fold a drop, and it is useful for technicians to be aware of the various methods. The method described below is how the drop should be folded at Tech Challenge.

Tech Challenge Event: Fold a theatrical backdrop

Team Event. The team can only have four members.

The team gets two attempts.

In this challenge, a team must fold a theatrical backdrop (or leg or teaser) for storage. The drop will be laid on the floor. The team members should plan who will be at each corner as the drop is folded and who should check for the crispness of each fold or pleat. Maximum time allotted is three (3) minutes.

Rules and required sequence

1. Leave the start line.
2. Make first fold. The team must fold the **pipe pocket**, lower corners, to the **webbing** (top), upper corners. Drop should be folded to the top where the tie lines are. The label should be plainly visible.

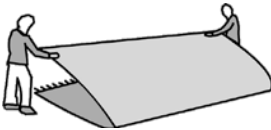

3. Fold again from lower edge to the webbing, smoothing wrinkles.

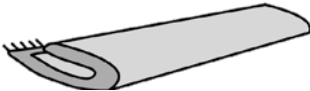

4. Continue folding until width is approximately three feet. Smoothing wrinkles and creases.

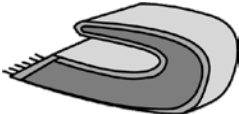

5. Fold hemmed edges towards the center. Leave space for the final book fold approximately 1' to 1'6".



6. Repeat until the backdrop can be folded into a square of two to three feet.



7. Fold the two halves of the drop back on themselves, creating a book-like shape with one open end.
8. Carry the folded drop and place it on the sizing template/in the storage box.
9. Team returns to the finish line and stops the timer.

Penalties: Fold a drop

Add the following time for:

- Way off center, not folding on center line 5 seconds
- Bad folds or pleats 5 seconds
- Did not work well as a team 5 seconds
- Label not visible 5 seconds
- Drop does not fit into sizing template 10 seconds
- Failure to follow the sequence 15 seconds

COSTUMING

Tech Challenge Event: Thread a sewing machine

Event: Thread a Sewing Machine

Individual Event

Two people per team can try this event, and each one gets two tries.

Each participant will insert a wound bobbin into the bobbin housing of a sewing machine and then properly thread the machine to pull the bobbin thread up through the stitch plate.

Equipment/Materials Required per Station

- Sewing machine* with needle in place
- Bobbins wound with thread
- Spools of thread
- Scissors
- Stopwatch

** Although most standard sewing machines thread the same, the machine supplied for the event will be a Singer Heavy Duty Basic Student Machine with a drop-in bobbin like the one pictured here.*



The maximum time allotted for this event is two (2) minutes.

Preset for Event

- Wound (filled) bobbin, spool of thread, and scissors should be placed on the table to the right of the machine.
- Bobbin housing cover should be in place on the machine.
- Thread spindle cap should be in place on the machine.

Required sequence

1. Leave the starting line.
2. Remove bobbin housing cover.
3. Insert the bobbin into the bobbin housing with thread unwinding counterclockwise.
4. Remove thread spool cap and place thread on spindle.
5. Replace thread cap and thread the machine following the thread guide on the machine.
6. Thread the needle.
7. Turn the flywheel and pull bobbin thread up through the sewing plate on the machine.
8. Pull thread under the pressure foot to the back of the machine.
9. Replace bobbin housing cover.
10. Return to starting line to stop time.

Penalties: Thread a sewing machine

Add the following time for:

Careless handling of equipment	5 seconds
Incorrect threading sequence	5 seconds
Incorrect insertion of bobbin into housing	5 seconds

SCENERY

Tech Challenge Event: Leg a platform

Pair event

One pair per team and they get two attempts.

In this challenge, if one platform is available, then the pair must attach two legs and remove two legs, leaving the platform ready for the next team: two legs are bolted to the platform and two not. If two platforms are available, then the team must attach four legs and remove four legs, leaving the platforms ready for the next team: one platform set with four legs bolted and one with none.

Platforms are 3' x 3', framed with 2x4s, and have a 2x4-leg for each corner. The leg holes are drilled slightly larger than the 3/8-inch bolts used to attach them to the platforms. Two ratchets and two adjustable wrenches are provided. Participants must set the ratchet in forward/reverse mode and get the adjustable wrench set to the correct width.

Maximum time allotted is five (5) minutes.

Rules and required sequence: one platform

1. Leave the start line.
2. Each member grabs a leg, wrenches, and hardware.
3. Each attaches a leg. Each participant will use a wrench and a ratchet.
4. Pair uses the same tools to remove the other leg.
5. Pair returns to the finish line and stops the timer.

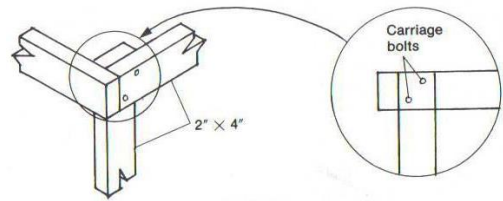

Rules and required sequence: two platforms

1. When the pair has legged the platform, they flip it, putting it on its marks.
2. Return to finish line and stops the timer.

Penalties: Leg a platform

Add the following time for:

- Loose legs
 - Small wiggle 5 seconds
 - Medium wiggle 10 seconds
 - Very loose wiggle 15 seconds
- Placing any items in mouth 10 seconds
- Not all team members attached one leg 20 seconds
- Not set in spike marks correctly (two-platform event) 10 seconds
- Bolts attached backwards (nuts on outside) 5 seconds
- Failure to follow the sequence 5 seconds
- Blatant disregard for the rules disqualified